

CENTAJOINT®

The multi functional drive shaft
Die universelle Antriebswelle

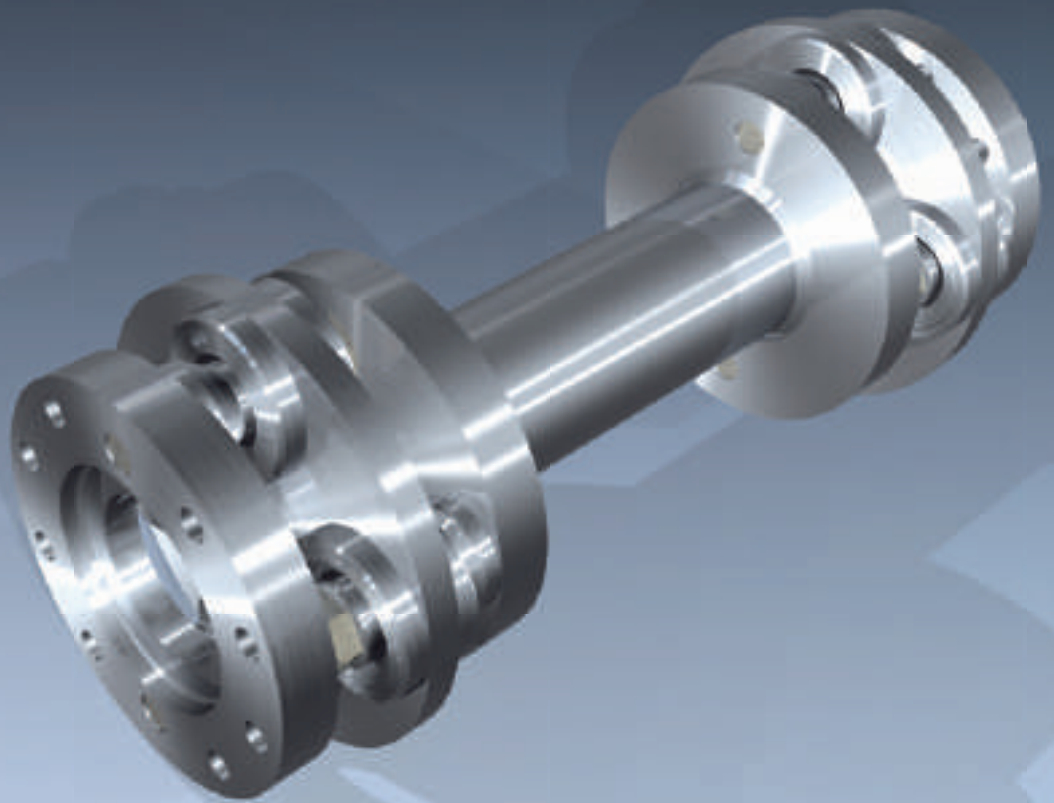

The new jointsystem CENTAJOINT

The application varieties for the new CENTAJOINT system are almost unlimited. This unique universal joint shaft finds its application in ship propulsions, rail systems, wind energy, cooling towers, ventilator drives, mills and calanders. The CENTAJOINT - a real „all-rounder“ due to its ability for misalignment almost providing unlimited applications in all kinds of power transmissions.

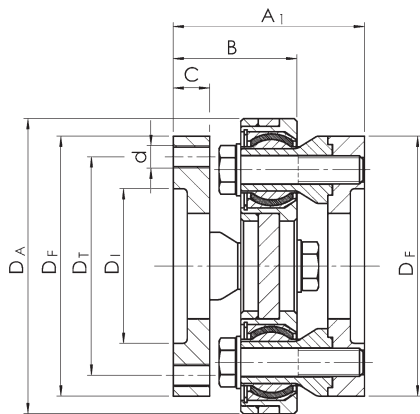

Single Joint
Einzelnes Gelenk

Das neue Gelenksystem CENTAJOINT

Die Verwendungsmöglichkeiten der neuen CENTAJOINT sind äusserst vielfältig. Die weltweit einzigartige Gelenkwelle findet ihre wichtigsten Einsatzgebiete in Schiffsantrieben, bei Schienenfahrzeugen, Windkraftwerken, Kühltürmen, Ventilatorantrieben, Mühlen und Kalandr Walzwerken. Die CENTAJOINT, ein wahrer Alleskönner, die Verwendungsmöglichkeiten in verschiedensten Antriebskonstruktionen sind durch ihre Verlagerungsfähigkeit nahezu unbegrenzt.

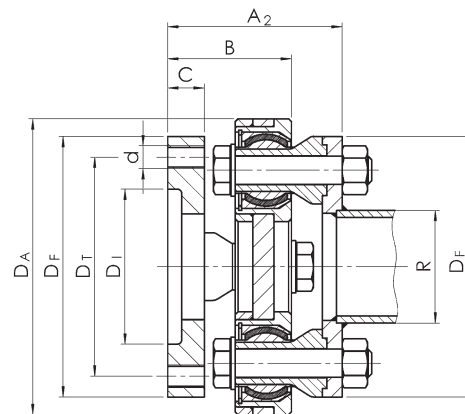

Joint with tube for the connection of a further joint
Gelenk mit Rohr zum Anschluss eines weiteren Gelenkes

CENTAX Size CENTAX Größe	U-joint Flange CENTA Ordercode Kardanflansch CENTA Bestellcode	Nominal torque Nenn-drehmoment T_{KN} [kNm]	Max. torque Max. Drehmoment T_{Kmax} [kNm]	Max. Speed Max. Drehzahl n_{max} [min ⁻¹]	Angular Deflection Winkelige Auslegung K_{Wmax} [°]*	A ₁	A ₂	B	C	D _A		DF	R	AGM size AGM Grösse **
						[mm]	[mm]	[mm]	[mm]	stand. [mm]	sond. [mm]	[mm]	[mm]	[mm]
201	100/120/121	1,10	3,30	3000	3,0					180	170	155	60	50
202	100/120/121/150/151	1,25	3,75	3000	3,0					190	180	165	65	80
203	120/121/150/151/180/181	1,65	4,95	3000	3,0	136	124	88	26	210	200	185	80	140
204	150/151/180/181/225/226	2,20	6,60	2800	3,0					250	240	225	100	200
205	180/181/225/226/250	2,50	7,50	2800	3,0					275	265	250	100	200
301	180/181/225/226/250	4,00	12,00	2500	3,0					278	265	250	120	250
302	225/226/250/285	5,00	15,00	2400	3,0	184	169	116	34	313	300	285	120	400
303	250/285/315	6,00	18,00	2400	3,0					343	330	315	120	400
401	250/285/315	10,00	30,00	2200	3,0					371	350	315	145	600
402	285/315/350	12,00	36,00	2000	3,0	237	217	153	44	416	395	360	145	600
403	315/350/390	14,00	42,00	2000	3,0					416	425	390	145	-

* Deflection applies to transient operation.
For continuous deflection following applies $K_{Wcont} = 0,65 \times K_{Wmax}$
**This size of CF-AGM has been assigned to this CENTAJOINT.

* Die Auslenkung gilt für transiente Vorgänge.
Für dauernde Auslenkung gilt: $K_{Wcont} = 0,65 \times K_{Wmax}$
**Diese Grösse der CF-AGM ist dieser CENTAJOINT zugeordnet.

Connecting dimensions for cardan flanges		Anschlussmaße für Kardanwellen			
D _k	Ordercode Bestellcode	D ₁	D _T	N	d
Cardan flange outer diameter Kardanflansch Aussen ø		f7	±0,1		
100	100	57	84	6 x 60°	M 8
120	120	75	101,5	8 x 45°	M 10
	121	75	101,5	8 x 45°	M 8
150	150	90	130	8 x 45°	M 12
	151	90	130	8 x 45°	M 10
180	180	110	155,5	8 x 45°	M 14
	181	110	155,5	10 x 36°	M 16

Connecting dimensions for cardan flanges		Anschlussmaße für Kardanwellen			
D _k	Ordercode Bestellcode	D ₁	D _T	N	d
Cardan flange outer diameter Kardanflansch Aussen ø		f7	±0,1		
225	225	140	196	8 x 45°	M 16
	226	140	196	12 x 30°	M 16
250	250	140	218	8 x 45°	M 18
285	285	175	245	8 x 45°	M 20
315	315	175	280	8 x 45°	M 22
350	350	220	310	10 x 36°	M 22
390	390	250	345	10 x 36°	M 24